



PUMPS

Maximize Pump Life with Permanent Bearing Protection.

Pumps are vital to the industrial process and are designed to operate for many years, yet they consistently come out of service due to product leakage from mechanical seal failure. Mechanical seals can fail as a result of axial movement and shaft deflection caused by bearing damage – leading to catastrophic bearing failure.

A majority of bearing damage is due to ineffective sealing solutions allowing contamination to enter the bearing housing and lubrication loss. Commonly used contact seals either wear at the point of contact or groove the shaft, rendering them ineffective in a short time.

Increase reliability and maximize the life of your pumps with permanent bearing protection from Inpro/Seal®. The compact design of the Inpro/Seal VB45-S™ Bearing Isolator is IP66 rated for premium contamination protection. Utilizing the VBXX® interface and VBX®-Ring, the VB45-S permanently keeps contaminants from entering the bearing housing while the innovative D-Groove ensures lubrication retention by capturing lubricant and directing it back into the bearing housing.

Unscheduled downtime can be costly, but don't worry, Inpro/Seal has you covered. We've streamlined our operation process to offer same day shipments, even on new designs, to get your equipment running right away.

Count on us to improve pump reliability, increase MTBR, and maximize pump life. We are the trusted source of Bearing Isolator technology with over 40 years of knowledge and real world experience to design the right custom engineered solution for you.

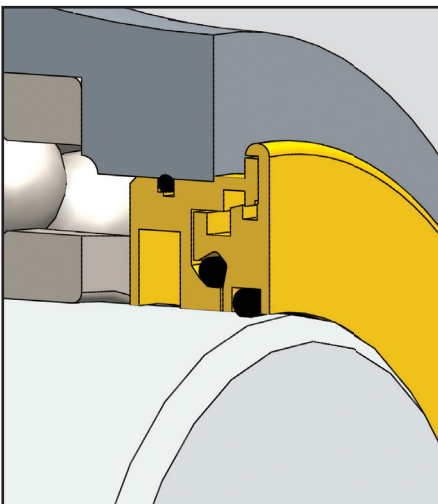

VB45-S Bearing Isolator

ADVANTAGES

Inpro/Seal Bearing Isolators:

- Increase bearing life and reliability – maximizing the life of your mechanical seal and the uptime of your pump.
- Permanently protect against contamination ingress and lubrication loss.
- Can be installed on a majority of pump types including process, API, end suction, slurry, vertical, sleeve bearing, positive displacement and horizontal split case.
- Can be designed for multiple lubrication types including grease, oil splash, oil forced, pure mist and purge mist.
- Lower emissions by sealing against harmful VOCs.
- Increase energy efficiency by not creating drag on the shaft.
- Can be shipped the same day your order is placed.



www.inpro-seal.com | info@inpro-seal.com

